

New  
Specification



Rewarding Learning

General Certificate of Secondary Education  
2018

Centre Number

--	--	--	--	--

Candidate Number

--	--	--	--	--

## Technology and Design

Unit 1:

Technology and  
Design Core Content

[GTY11]

WEDNESDAY 23 MAY, MORNING



\*GTY11\*

### TIME

1 hour 30 minutes.

### INSTRUCTIONS TO CANDIDATES

Write your Centre Number and Candidate Number in the spaces provided at the top of this page.

**You must answer the questions in the spaces provided.**

**Do not write outside the boxed area on each page or on blank pages.**

Questions which require drawing or sketching should be completed using an H.B. pencil.

All other questions must be completed using black ink only.

**Do not write in pencil or with a gel pen.**

Answer **all ten** questions.

### INFORMATION FOR CANDIDATES

The total mark for this paper is 100.

Quality of written communication will be assessed in Question **10**.

Figures in brackets printed down the right-hand side of pages indicate the marks awarded to each question or part question.

The Formula sheet is on page 3.

11407



\*28GTY1101\*

**BLANK PAGE**  
**DO NOT WRITE ON THIS PAGE**

11407



\*28GTY1102\*



## Formulae for GCSE Technology and Design

You should use, where appropriate, the formulae given below when answering questions which include calculations.



- 1 Potential Difference = current  $\times$  resistance ( $V = I \times R$ )
- 2 Series Resistors  $R_t = R_1 + R_2 + \dots + R_n$
- 3 Gear ratio of a simple gear train =  $\frac{\text{number of teeth on driven gear}}{\text{number of teeth on driver gear}}$
- 4 Velocity ratio =  $\frac{\text{diameter of driven}}{\text{diameter of driver}}$



1 **Table 1** refers to a number of symbols.

(a) Using the first row as a guide, complete the table.

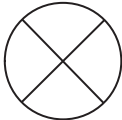
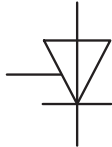
**Table 1**

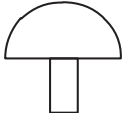
Sketch of Symbol	Type of Symbol	Name of Symbol
	Electronic	Bulb
	Electronic	
		Knife follower
	Flowchart	
		

[6]



(b) **Table 1** shows a flowchart symbol.

Sketch and name another flowchart symbol (other than a Start/Stop flowchart symbol).

Sketch

[1]

Name: \_\_\_\_\_ [1]

(c) (i) One of the electronic symbols shown in **Table 1** is reproduced as **Fig. 1** below. Is this component used as an input, process or output component in an electronic circuit?

[1]

(ii) Identify each of the terminals labelled **X**, **Y** and **Z**.

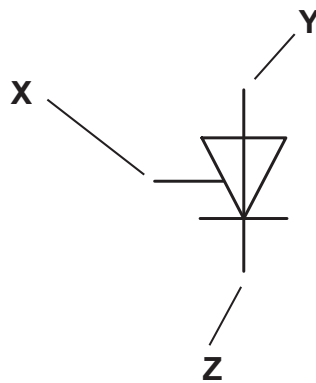

**Fig. 1**

Terminal X \_\_\_\_\_

Terminal Y \_\_\_\_\_

Terminal Z \_\_\_\_\_ [3]

**[Turn over**



- 2 Fig. 2 shows a sketch of the lid for a box. The two materials used in the manufacture of the lid are acrylic and beech. The acrylic part of the lid is to be produced using a CAD/CNC process in a school workshop.

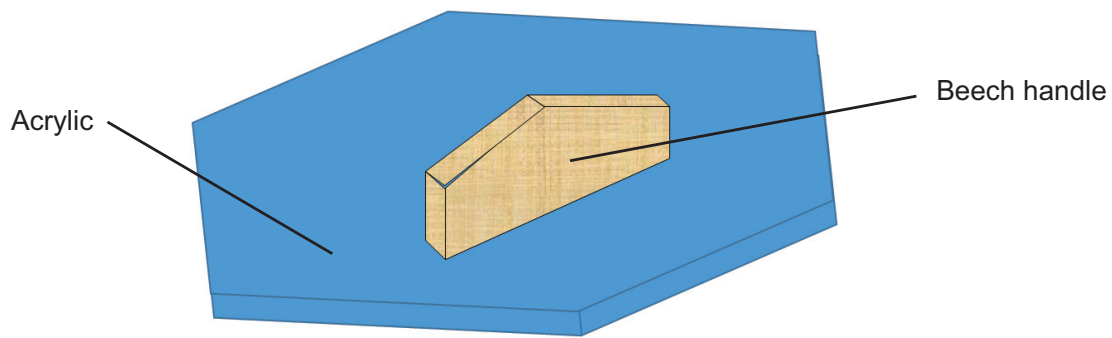

Fig. 2

Source: © Principal Examiner CCEA

- (a) Is beech a hardwood or a softwood material?

\_\_\_\_\_ [1]

- (b) Most CAD software enables the design to be tested on a computer.

Identify **three** reasons for testing the design on a computer.

Reason 1

\_\_\_\_\_  
\_\_\_\_\_ [1]

Reason 2

\_\_\_\_\_  
\_\_\_\_\_ [1]

Reason 3

\_\_\_\_\_  
\_\_\_\_\_ [1]



(c) The **six** bullet points below describe, in order, the stages for the production of the acrylic lid using a CNC machine.

Complete **Fig. 3** by **summarising** each of the bullet points as a key factor of each stage listed.

The first bullet point has been done as an example.

- The design of the acrylic lid is loaded into the computer which is attached to a CNC machine. The computer converts the design to a numerical code that controls the way the CNC cuts and shapes the material.
- The acrylic to be shaped is taped on to a block of wood with double sided tape. This must be done carefully so that it does not come off the block during machining.
- The block of wood with the attached acrylic is then placed on the worktable, inside the CNC machine. It must be tightened up carefully using clamps. If it is not secure when the machine starts to cut the acrylic, the wooden block can come away from the clamps.
- The guard is then locked in position. It protects the machine operator in case the material is pulled out of the clamps by the power of the cutter. For safety reasons, if the guard is not in position the motor will not start.
- The CNC machine is turned on and the shape is cut from the acrylic.
- When the cutter has stopped, the shaped material can be removed from the CNC machine.

**Stages in the CNC process:**

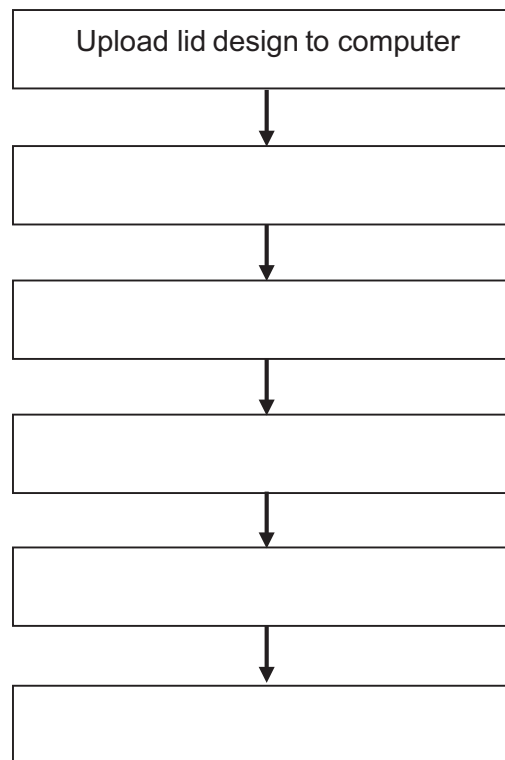

**Fig. 3**

**[5]**

**[Turn over**



(d) Fig. 4 shows two views of the beech handle. Two pilot holes of 4 mm diameter are required, for attaching the handle to the lid with wood screws.

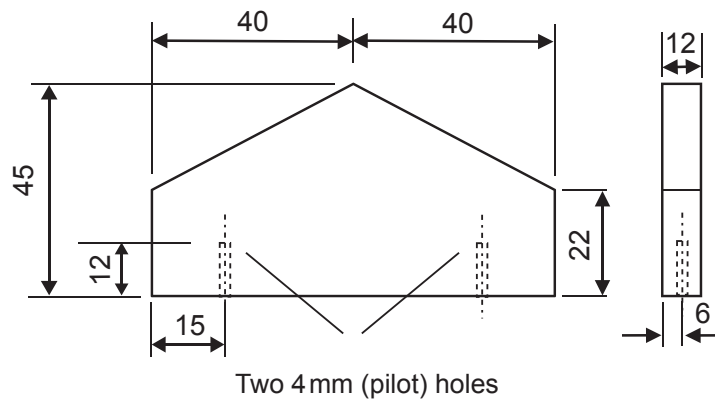

All dimensions are in mm

**Fig. 4**

Source: © Principal Examiner CCEA

Outline **four** stages in the marking out and drilling of the holes using a pillar drilling machine.

- 1 \_\_\_\_\_
- \_\_\_\_\_
- 2 \_\_\_\_\_
- \_\_\_\_\_
- 3 \_\_\_\_\_
- \_\_\_\_\_
- 4 \_\_\_\_\_
- \_\_\_\_\_

[4]



3 (a) Fig. 5 below shows the pulley system which connects a motor to a pillar drill.

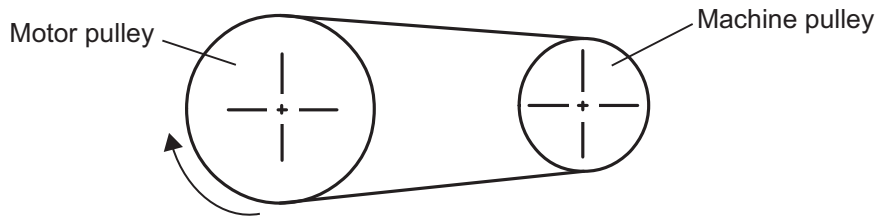

Fig. 5

Complete each of the following by placing a tick in the correct box.

(i) The machine pulley rotates:

clockwise

anticlockwise

[1]

(ii) The motor pulley is the:

driver pulley

driven pulley

[1]

(iii) The machine pulley is the:

low speed pulley

high speed pulley

[1]

(iv) Which type of pulley belt would be used for this system?

A vee belt

A round belt

[1]

[Turn over



(b) Fig. 6 below shows two pulleys labelled (i) and (ii).

Sketch on the diagram, the belt drive to make the machine pulley rotate anticlockwise.

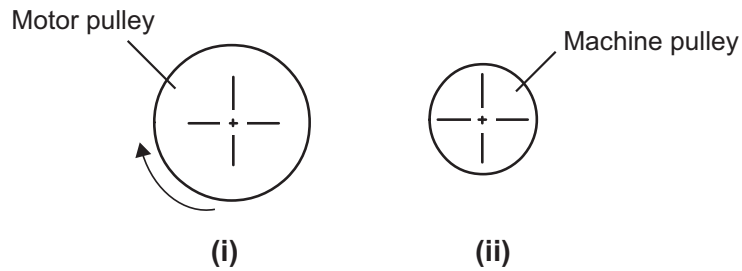

Fig. 6

[1]

(c) Outline **three** advantages of using a pulley system compared to a simple gear train.

1 \_\_\_\_\_

\_\_\_\_\_

2 \_\_\_\_\_

\_\_\_\_\_

3 \_\_\_\_\_



\_\_\_\_\_

[3]

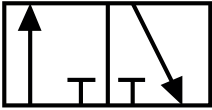
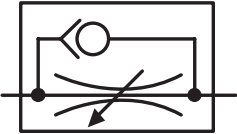

4 **Table 2** shows a number of pneumatic symbols.

**Table 2**

Pneumatic Symbol	Letter for Symbol Name
	
	
	
	

[4]

(a) Complete **Table 2** by selecting the correct letter for each symbol from **Table 3** below:

**Table 3**

Name	Letter
3/2 Valve	A
Single acting cylinder	B
Lever	C
Shuttle valve	D
Unidirectional flow restrictor	E
Roller trip	F
Pressure source	G

[Turn over



(b) State the name of the valves in Table 3 that would be used to control:

(i) the direction of movement of a single acting cylinder.

\_\_\_\_\_ [1]

(ii) the speed of a single acting cylinder.

\_\_\_\_\_ [1]

(c) Describe two safety precautions which should be followed when building a pneumatic circuit.

\_\_\_\_\_  
\_\_\_\_\_  
\_\_\_\_\_  
\_\_\_\_\_ [2]



5 Fig. 7 shows five tools labelled A, B, C, D and E.

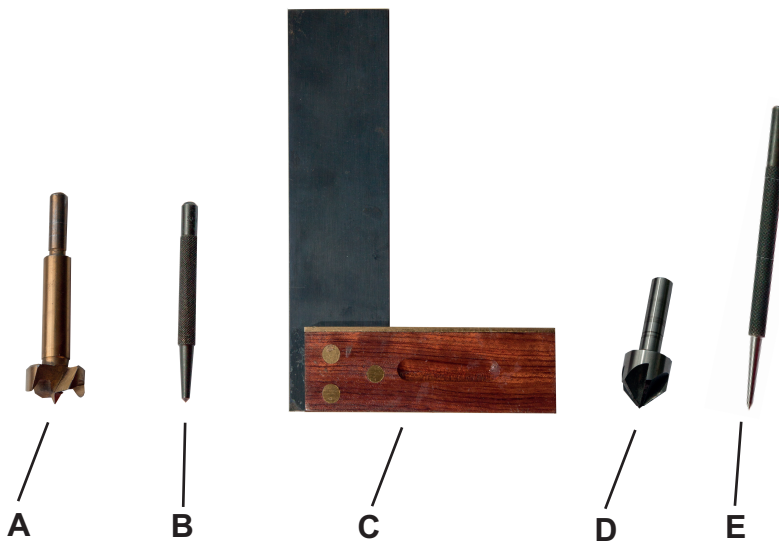

Fig. 7

Source: © Chief Examiner

(a) (i) Complete **Table 4** by inserting the correct letter from **Fig. 7** to match the image with the name of the tool.

Table 4

Name of Tool	Letter
Try Square	
Countersunk Bit	
Centre Punch	
Scriber	
Forstner Bit	

[5]

(ii) Explain the purpose of using a countersunk bit.

---



---

[2]

[Turn over



**(b) (i)** Other than cost, outline **two** advantages that a manufactured board has compared to natural timber.

1 \_\_\_\_\_

2 \_\_\_\_\_ [2]

**(ii)** Explain the difference between Aluminium and an Aluminium alloy.

\_\_\_\_\_

\_\_\_\_\_ [2]





**BLANK PAGE**

**DO NOT WRITE ON THIS PAGE**

**(Questions continue overleaf)**

11407

**[Turn over**



\*28GTY1115\*

- 6 (a) Name the electronic components represented by the symbols labelled **X** and **Y** in **Fig. 8** below.

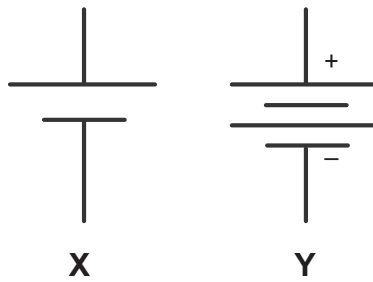
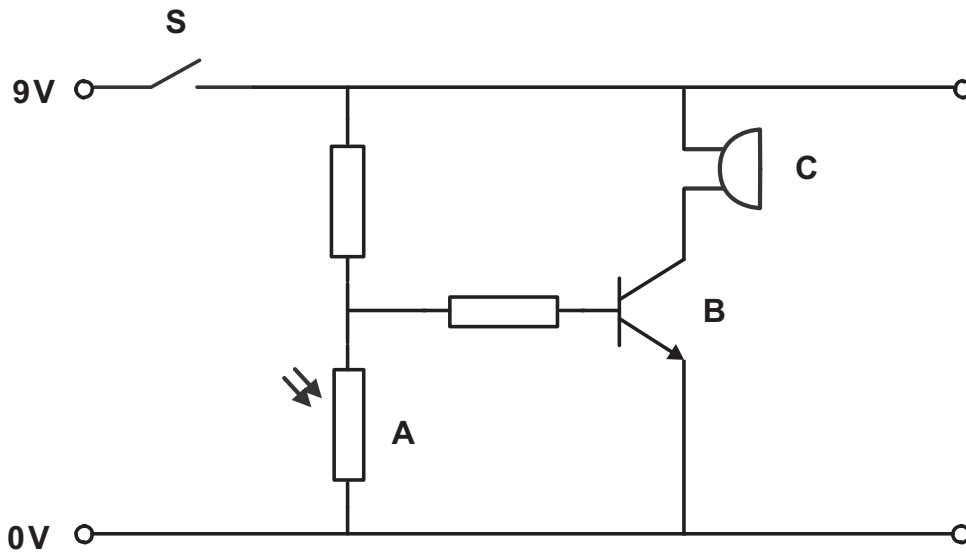

**Fig. 8**

X \_\_\_\_\_ [1]

Y \_\_\_\_\_ [1]

- (b) An electronic circuit is shown in **Fig. 9**.



**Fig. 9**





(i) Name the electronic components represented by the electronic symbols labelled **A** and **B** in **Fig. 9**.

Symbol **A**: \_\_\_\_\_ [1]

Symbol **B**: \_\_\_\_\_ [1]

(ii) Explain how the circuit in **Fig. 9** operates the buzzer labelled **C**.

---

---

---

---

[4]



- 7 **Fig. 10** shows a plan view of a two way directional parcel conveyor system with a robotic arm. The parcels travel along the conveyor system and are redirected at set times by a robotic arm.

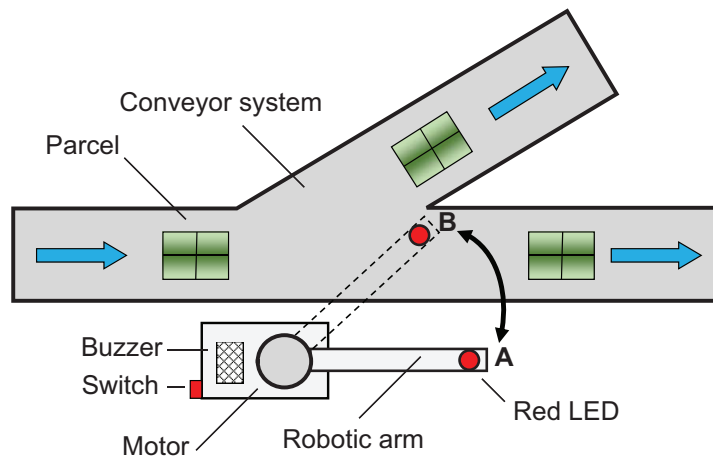

Source: © Principal Examiner CCEA

**Fig. 10**

When the switch is pressed, the red LED comes on and the buzzer sounds. After ten seconds the motor in the robotic arm starts to turn anticlockwise to position 'B'. It switches off after five seconds. It remains in position 'B' for sixty seconds. The motor then turns clockwise to position 'A' and switches off after five seconds. The red LED and buzzer both switch off three seconds later. The robotic arm remains stationary for a further ninety seconds. The sequence then repeats.

Complete the flow chart in **Fig. 11** to illustrate the program to run the robotic arm system.



START



[14]

Fig. 11

[Turn over

11407



\*28GTY1119\*

8 Fig. 12 shows a mechanical control symbol.

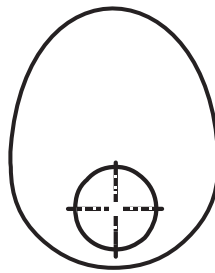

Fig. 12

(a) Name the symbol shown in Fig. 12.

\_\_\_\_\_ [1]

(b) Fig. 13 shows the outline of a boat that is activated from a coin operated money box used by the Royal National Lifeboat Institute (RNLI). The boat is attached to a lever which has a fixed point **A** and is moved by the driving mechanism **B**. The boat moves when a coin is dropped into the money box.

The driving mechanism **B** moves the lever about the fixed point **A**.

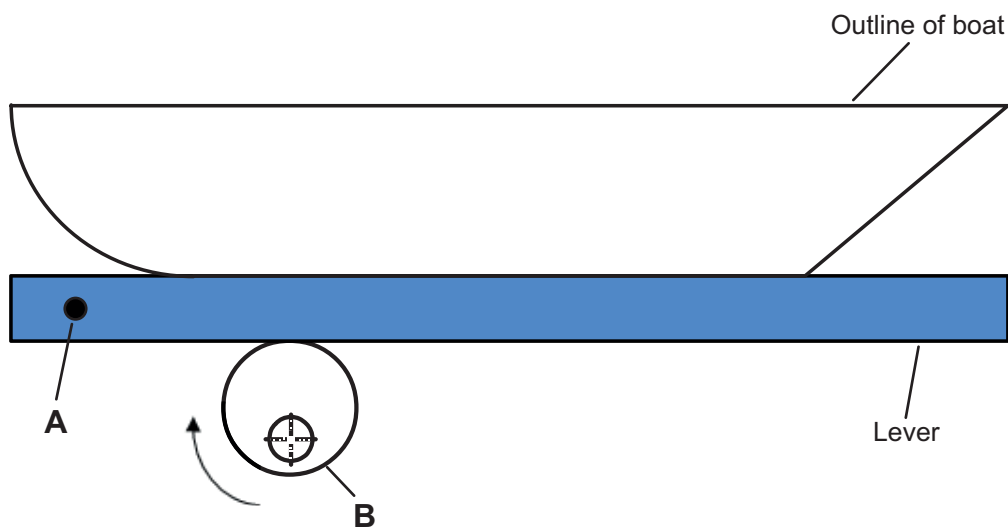

Fig. 13

Source: © Principal Examiner CCEA





(i) Name the driving mechanism **B** shown in **Fig. 13**.

\_\_\_\_\_ [1]

(ii) Give another name for the fixed point **A** shown in **Fig. 13**.

\_\_\_\_\_ [1]

(iii) Identify the class of lever shown in **Fig. 13**.

\_\_\_\_\_ [1]

(iv) When operated, it was found that the boat did not always fall with the rotation of the driving mechanism **B**. Outline **two** reasons why this could happen.

\_\_\_\_\_  
\_\_\_\_\_  
\_\_\_\_\_  
\_\_\_\_\_ [2]

(v) Describe **two** methods of overcoming this problem.

\_\_\_\_\_  
\_\_\_\_\_  
\_\_\_\_\_  
\_\_\_\_\_ [2]

[Turn over



9 Fig. 14 shows a pneumatic circuit that could be used in a baggage handling system.

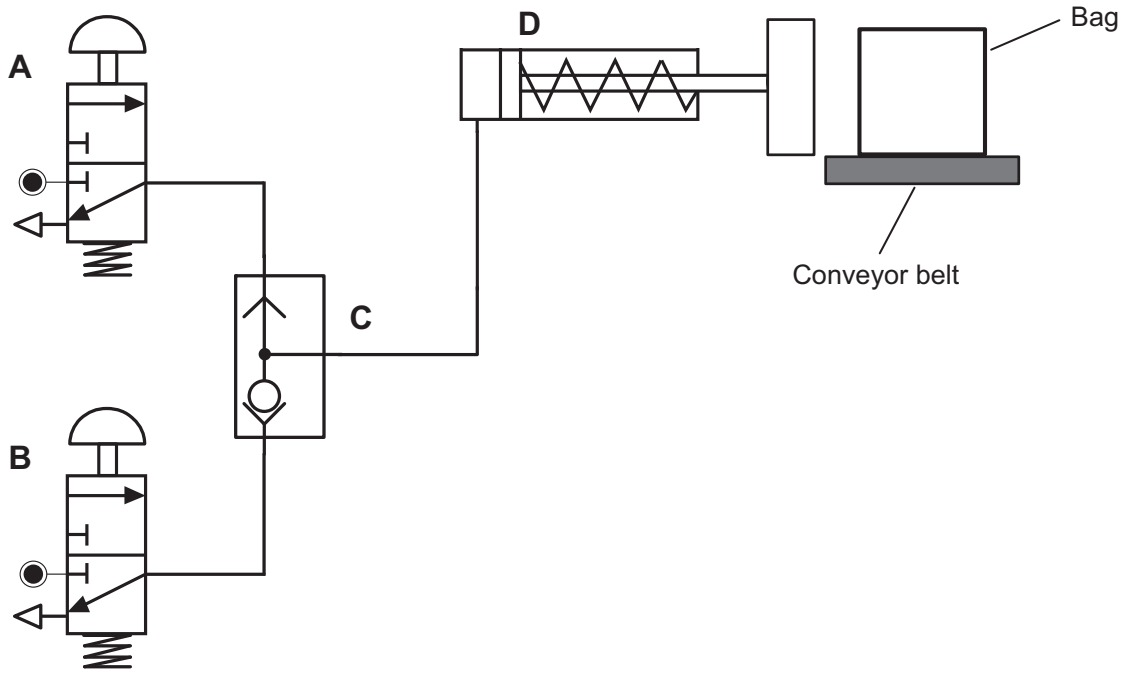

Fig.14

(a) (i) Name the method of operation used in Valve A.

\_\_\_\_\_ [1]

(ii) Name Valve C.

\_\_\_\_\_ [1]

(iii) Explain why two valves, to activate the circuit, are included.

\_\_\_\_\_ [1]

(b) (i) Suggest **two** features which should be considered in selecting component D.

1 \_\_\_\_\_ [1]

2 \_\_\_\_\_ [1]

(ii) State the type of logic connection used in this circuit.

\_\_\_\_\_ [1]



(c) On testing the baggage handling system it was found that the bags were being damaged. Explain how the circuit could be developed to prevent this from happening.

---

---

---

[2]

[Turn over

11407



\*28GTY1123\*





**BLANK PAGE**  
**DO NOT WRITE ON THIS PAGE**

11407



\*28GTY1126\*





**BLANK PAGE**  
**DO NOT WRITE ON THIS PAGE**

11407



\*28GTY1127\*

**DO NOT WRITE ON THIS PAGE**

For Examiner's use only	
Question Number	Marks
1	
2	
3	
4	
5	
6	
7	
8	
9	
10	

<b>Total Marks</b>	
--------------------	--

Examiner Number

Permission to reproduce all copyright material has been applied for.  
In some cases, efforts to contact copyright holders may have been unsuccessful and CCEA will be happy to rectify any omissions of acknowledgement in future if notified.

11407



\*28GTY1128\*